

# SL38W

SL38W Wheel Loader



## SUNWARD

### Features:

- ★ Single lever joystick control system, comfortable and flexible operation;
- ★ Air over hydraulic disks on four wheel brakes;
- ★ Double sealed hydraulic pipeline joints with 24°awl and O ring of international standard, avoiding oil leakage;
- ★ Integral, luxury instrument board

## Features:

- ★ Weichai DEUTZ WP6G125E23 diesel engine, higher power and reliability;
- ★ Hydrodynamic transmission, three-element and single stage torque converter, high reliability, easy maintenance;
- ★ Hangzhou Advance Gearbox Group BS428 power shift transmission, high efficiency and easy maintenance;
- ★ Gear-shift controlled by flexible shaft makes operation more flexible and reliable;
- ★ Large space articulated frames make operation and traveling stable;
- ★ Working device with automatically leveling ability at high position;
- ★ Bucket articulated points take sealed, lubricated, dust-proof layers, which owns good durability;
- ★ New, luxury cabin.

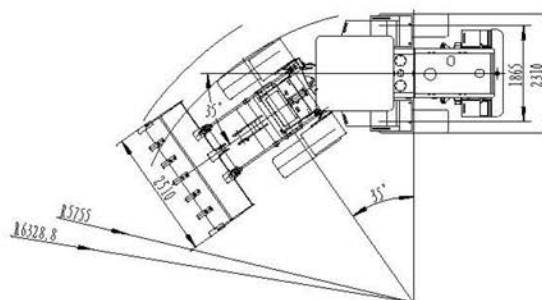
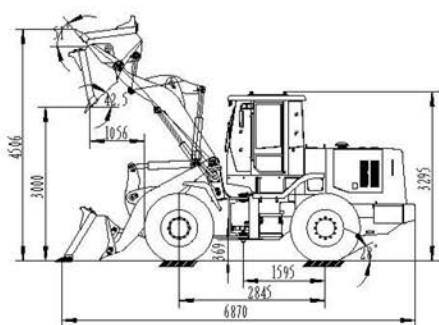

## Main Specifications:

Item	Specification	Item	Specification
Bucket capacity	1.8m <sup>3</sup>	Min. turning radius (outside of rear wheel)	5755mm
Rated load	3000kg	Steering angle	36°
Dumping height	3000mm	Min. ground clearance	369mm
Dumping reach	1056mm	Wheel base	2845mm
Boom lifting time	5.5s	Wheel tread	1865mm
Max. speed	36km/h	Rated power	92kW/2300rpm
Max. breakout force	103kN	Tyre	17.5-25
Max. drawing force	90kN	Overall dimensions	6870*2510*3295mm
Max. grade ability	28°	Operating weight	10500kg

Remark : heavy chassis for standard

## Optional:

- (1) Dongfeng Cummins 6BT5.9-C130 engine (97Kw/ Euro I)
- (2) ZF Tech YD13 electronic control gearbox from Hangzhou Advance Gearbox Group
- (3) Air Condition
- (4) Joystick control
- (5) Quick-hitch
- (6) Fork
- (7) ROPS

# SL58W

SL58W Wheel Loader



## SUNWARD

### Features:

- ★ Twin pump merging hydraulic system makes lower consumption and excellent performance.
- ★ Both travel system and working hydraulic system are forced-cooled, improving the efficiency obviously.
- ★ The coaxes flow-amplified, hydraulic compensated steering makes operation easy and performance reliable.
- ★ Air over hydraulic brake system; eight caliper disc brakes.



## Features:

- ★ Weichai Steyr WD10G220E21diesel engine is adopted, large torque backup and strong power.
- ★ Single stage, 4 elements, twin turbo ZL50 torque converter and planetary gearbox from Hangzhou Advance Gearbox Group, compact structure and high reliability.
- ★ Gear-shift with 2 forward and 1 reverse controlled by flexible shaft eases much labor.
- ★ Integral, luxury instrument board
- ★ Air break control, expand hoof type parking brake and emergency brake.
- ★ Working device with automatically leveling ability at high position;
- ★ Bucket articulated points take sealed, lubricated, dust-proof layers, which owns good durability.
- ★ Strengthened axles owning large bearing capacities and high reliability.

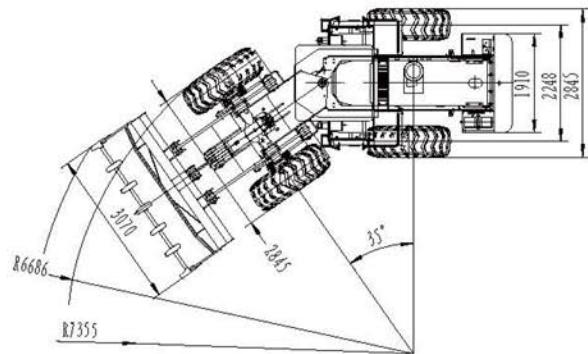
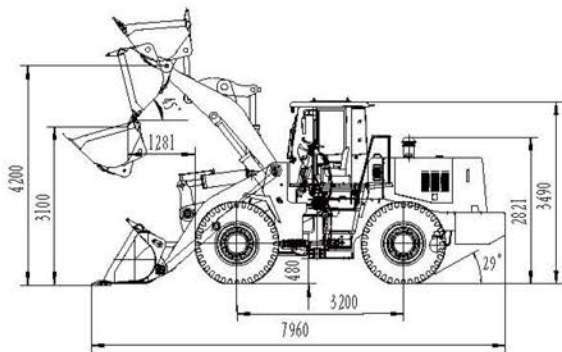

## Main Specifications:

Item	Specification	Item	Specification
Bucket capacity	3m <sup>3</sup>	Min. turning radius (outside of rear wheel)	6686mm
Rated load	5000kg	steering angle	35°
Dumping height	3100mm	Min. ground clearance	480mm
Dumping reach	1281mm	Wheel base	3200mm
Boom lifting time	6.8s	Wheel tread	2248mm
Max. speed	36km/h	Rated power	162kW/2200rpm
Max. breakout force	170kN	Tyre	23.5-25
Max. drawing force	150kN	Overall dimensions	7960*3070*3490mm
Max. grade ability	28°	Operating weight	17000kg

Remark: Heavy chassis for standard

## Optional:

- (1) Dongfeng Cummins 6CTA8.3-C215 engine
- (2) Air Condition
- (3) Joystick control
- (4) Quick-hitch

6CTA8.3-C215

- (5) Fork
- (6) ROPS